

TT-2023 Revision Lectures on **ELECTROMAGNETISM (CP2)**

Claire Gwenlan ¹

- Electrostatics
- Magnetostatics
- Induction
- EM waves

... taken from previous years' Prelims questions

¹ with thanks to Profs Hans Kraus, Laura Hertz and Neville Harnew

2 Magnetostatics

2.1. State the Biot-Savart Law which describes the magnetic flux density $d\mathbf{B}$ at a distance \mathbf{r} from a current element $I d\mathbf{l}$. [4]

Find the magnitude B of the magnetic flux density on the axis of a plane coil of n turns and radius a for a current I in the coil and at a distance z from the plane of the coil. [7]

State the Biot-Savart law :
Find the magnitude of \mathbf{B} on axis
for a coil of n turns.

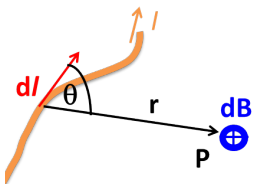
$$d\mathbf{B} = \mu_0 I \cdot \frac{d\mathbf{l} \times \hat{\mathbf{r}}}{4\pi r^2}$$

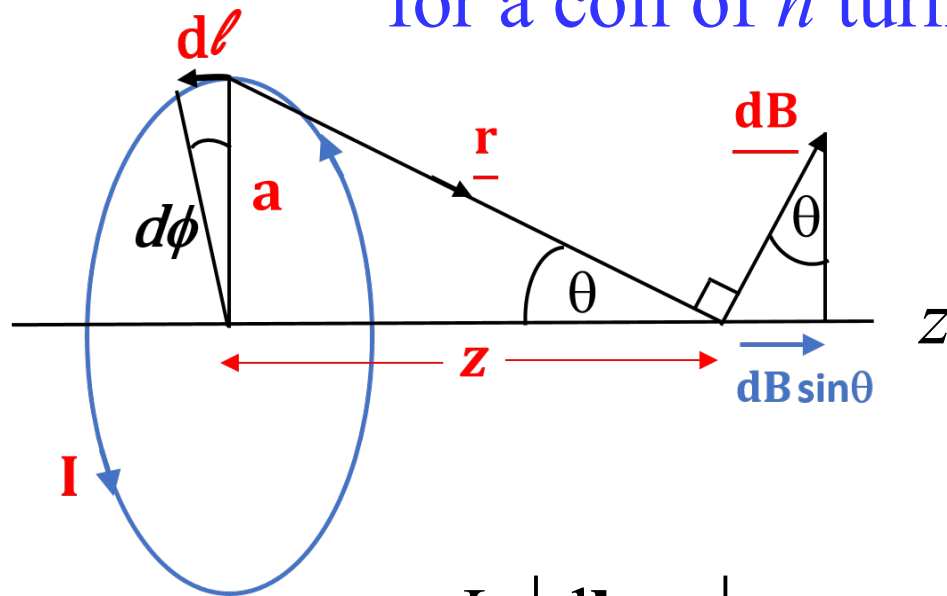

Symmetry:

$d\mathbf{B}$ has z -component only.

Perp. components cancel.

And also: $d\mathbf{l}$ is perp. to \mathbf{r}

$$\begin{aligned} \underline{\underline{B}} = B_z &= \int \frac{\mu_0 n I}{4\pi r^2} \cdot \underbrace{\left| \frac{d\mathbf{l} \times \mathbf{r}}{r} \right|}_{a/r} \cdot \underbrace{\sin\theta}_{a/r} = \int_0^{2\pi} \frac{\mu_0 n I a^2 d\varphi}{4\pi r^3} = \underline{\underline{\frac{\mu_0 n I a^2}{2(z^2 + a^2)^{3/2}}}} \end{aligned}$$

Two such coils are placed a distance d apart on the same axis. They are connected in series in such a way as to produce fields on the axis in the same direction. Write down an expression for the magnitude of the net field B' on the axis at a distance x from the point midway between the coils. [3]

Two such coils are placed a distance d apart on the same axis. Find B as function of x .

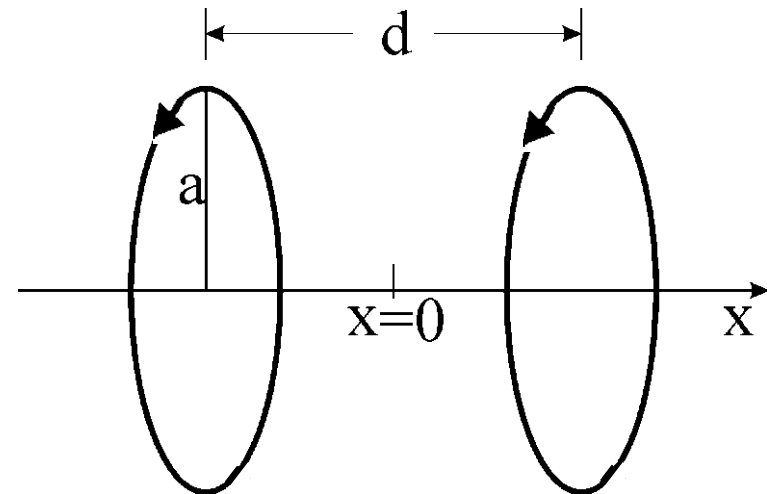

$$B'(x) = \frac{\mu_0 n I a^2}{2} \cdot \left[\frac{1}{\left(a^2 + \left(\frac{d}{2} + x \right)^2 \right)^{3/2}} + \frac{1}{\left(a^2 + \left(\frac{d}{2} - x \right)^2 \right)^{3/2}} \right]$$

Show that the derivative of B' with respect to x is zero when $x = 0$. Find the value of d for which the second derivative of B' with respect to x is also zero at $x = 0$. Under these conditions, show that the variation of B' between $x = 0$ and $x = d/2$ is less than 6 percent. [11]

$$B'(x) = \frac{\mu_0 n I a^2}{2} \cdot \left[\frac{1}{\left(a^2 + \left(\frac{d}{2} + x\right)^2\right)^{3/2}} + \frac{1}{\left(a^2 + \left(\frac{d}{2} - x\right)^2\right)^{3/2}} \right]$$

Show that the derivative of B' is 0 for $x=0$

$$\left(a^2 + \left(\frac{d}{2} \pm x\right)^2\right)^{-3/2} \xrightarrow{\frac{d}{dx}} -\frac{3}{2} \left(a^2 + \left(\frac{d}{2} \pm x\right)^2\right)^{-5/2} \cdot 2 \left(\frac{d}{2} \pm x\right) \cdot (\pm 1)$$

which is \pm the same, when $x = 0$, hence: $\frac{dB'}{dx}(0) = 0$

Find the value of d for which the second derivative of $B'(0)$ is 0.

$$\partial_x B' \propto -3 \left(a^2 + \left(\frac{d}{2} + x \right)^2 \right)^{-5/2} \left(\frac{d}{2} + x \right) + 3 \left(a^2 + \left(\frac{d}{2} - x \right)^2 \right)^{-5/2} \left(\frac{d}{2} - x \right)$$

$$\begin{aligned} \partial_x^2 B' \propto & -3 \left(a^2 + \left(\frac{d}{2} + x \right)^2 \right)^{-5/2} + 15 \left(a^2 + \left(\frac{d}{2} + x \right)^2 \right)^{-7/2} \left(\frac{d}{2} + x \right)^2 \\ & -3 \left(a^2 + \left(\frac{d}{2} - x \right)^2 \right)^{-5/2} + 15 \left(a^2 + \left(\frac{d}{2} - x \right)^2 \right)^{-7/2} \left(\frac{d}{2} - x \right)^2 \end{aligned}$$

$$\partial_x^2 B'(0) \propto -3 \cdot \frac{2}{\left(a^2 + \left(\frac{d}{2} \right)^2 \right)^{7/2}} \cdot \left[\left(a^2 + \left(\frac{d}{2} \right)^2 \right) - 5 \left(\frac{d}{2} \right)^2 \right] = 0$$

$$a^2 - 4 \left(\frac{d}{2} \right)^2 = 0 \quad \underline{\underline{d = a}}$$

When $a = d$, show that the variation of B'
between $x=0$ and $x=d/2$ is $<6\%$

$$B'(x) = \frac{\mu_0 n I}{2a} \cdot \left[\frac{1}{\left(1 + \left(\frac{1}{2} + \frac{x}{d}\right)^2\right)^{3/2}} + \frac{1}{\left(1 + \left(\frac{1}{2} - \frac{x}{d}\right)^2\right)^{3/2}} \right]$$

$$B'(0) = \frac{\mu_0 n I}{2a} \cdot \frac{2}{\left(\frac{5}{4}\right)^{3/2}} \quad B'\left(\frac{d}{2}\right) = \frac{\mu_0 n I}{2a} \cdot \left[\frac{1}{(1+1)^{3/2}} + \frac{1}{1} \right]$$

$$B'(0) = B_0 \cdot 1.43108$$

$$B'\left(\frac{d}{2}\right) = B_0 \cdot 1.35355$$

$$\underline{\underline{\frac{\Delta B'}{\bar{B}'} = 5.57\%}}$$

Sketch of the field of a pair of Helmholtz coils

B in units of $\frac{\mu_0 n I}{2a}$

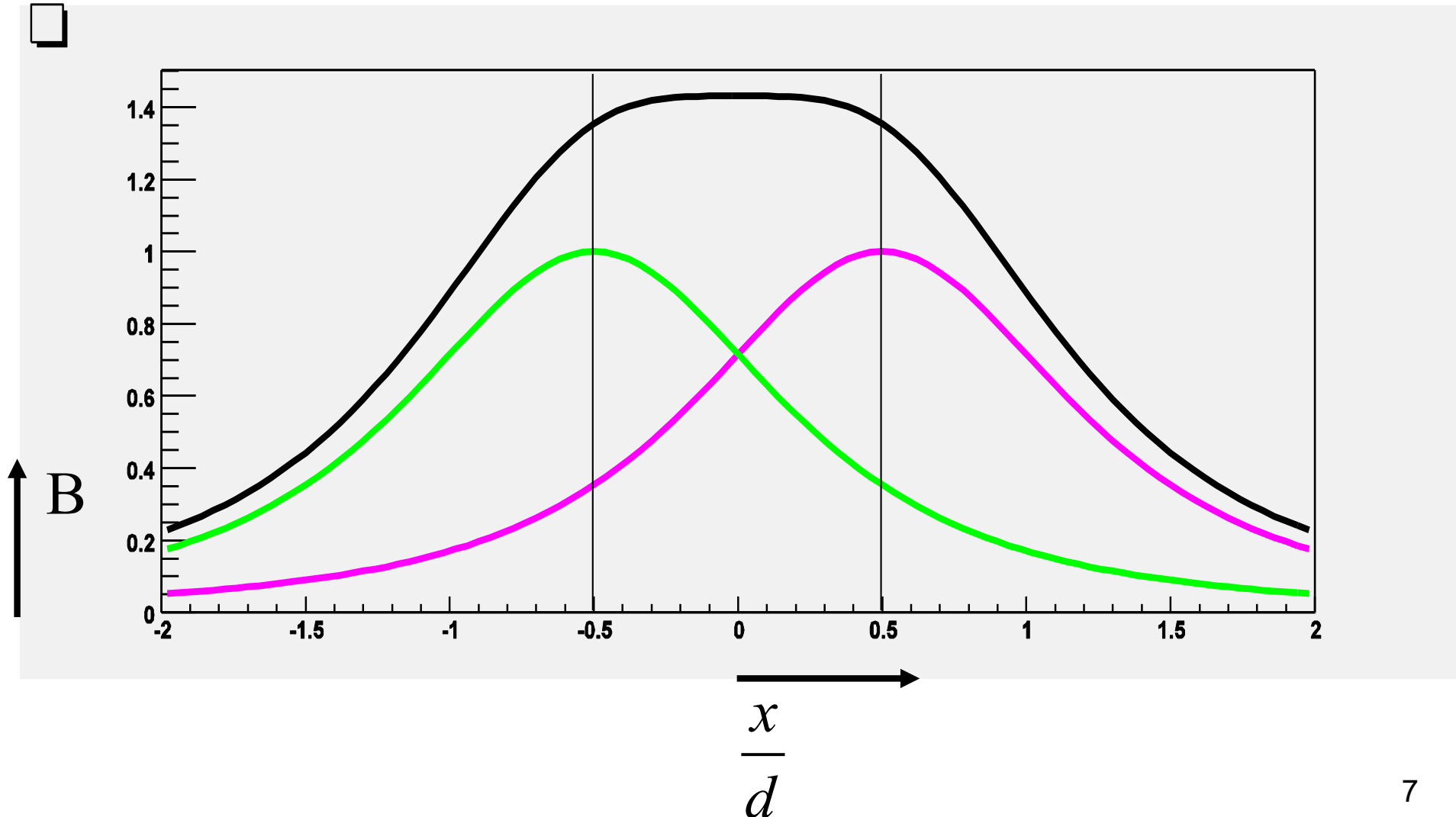

2.2. A very long cylindrical solenoid has radius R and is wound with N turns of wire per unit length. If the winding carries a current I , show that the magnetic induction B inside the coil is radially uniform and give an expression for its value. [8]

Ampere's law in its integral form: $\oint \mathbf{B} \cdot d\mathbf{l} = \mu_0 I$

N turns of wire per unit length.

(I enclosed)

Winding carries a current I .

Find B and show it is radially uniform inside the coil.

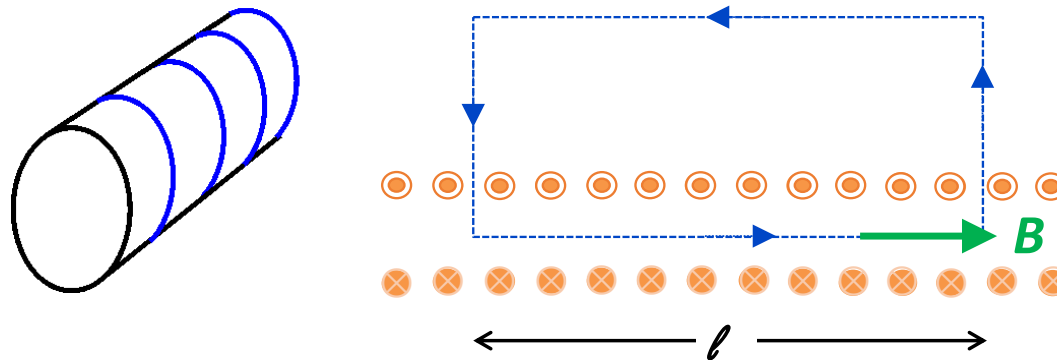

$$B \cdot \ell = \mu_0 \cdot N' \cdot I \quad \text{with} \quad N = \frac{N'}{\ell}, \quad \text{thus} \quad \underline{\underline{B = \mu_0 \cdot N \cdot I}}$$

For infinite solenoid, B constant within it (and zero outside)
 \rightarrow radially uniform field; symmetry means no azimuthal dependence⁸

Calculate the self-inductance per unit length of the solenoid.

[7]

Calculate the self-inductance per unit length.

$$L = \frac{\Phi_{tot}}{I} = \frac{B \cdot area}{I} \cdot turns = \frac{\mu_0 NI \cdot \pi R^2}{I} \cdot N\ell = \mu_0 N^2 \pi R^2 \ell$$

$$\dots \text{ and per length: } \underline{\underline{L/\ell = \mu_0 \pi R^2 N^2}}$$

A superconducting solenoid has radius 0.5 m, length 7 m and consists of 1000 turns. Calculate the magnetic induction in the solenoid, and the energy stored in it when it carries a current of 5000 A. You may approximate its behaviour to that of a very long solenoid.

[7]

Calculate the magnetic induction and the energy stored.

$$R = 0.5\text{m}, \quad \ell = 7\text{m}, \quad N' = 1000 \quad \Rightarrow \quad N = 142.86\text{m}^{-1}$$

$$\underline{\underline{B}} = \mu_0 NI = 4\pi \cdot 10^{-7} \frac{\text{Vs}}{\text{Am}} \cdot 142.86 \frac{1}{\text{m}} \cdot 5000\text{A} = \underline{\underline{0.897\text{T}}}$$

$$\underline{\underline{U_M}} = \frac{1}{2} LI^2 = \frac{1}{2} \mu_0 N^2 \pi R^2 \ell \cdot I^2 = \underline{\underline{1.76 \cdot 10^6 \text{J}}}$$

2.3. A long coaxial cable consists of two thin-walled coaxial cylinders of radii a and b . The space between the cylinders is maintained as a vacuum and a current I flows down the inner and returns along the outer cylinder. Calculate the magnetic field at a distance r from the axis when

(i) $b > r > a$, (ii) $r > b$ and (iii) $r < a$. [10]

Calculate magnetic field inside a pair of co-axial cylinders due to current I flowing as shown.

Ampere's Law: $\oint \mathbf{B} \cdot d\mathbf{l} = \iint \mathbf{J} \cdot d\mathbf{A} = \mu_0 I$

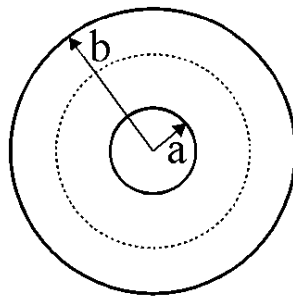
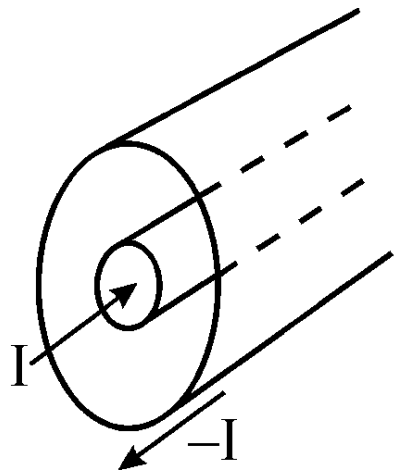

$$b > r > a: \quad 2\pi r B_\theta = \mu_0 I$$

$$r > b: \quad 2\pi r B_\theta = \mu_0 (I - I) = 0$$

$$r < a: \quad 2\pi r B_\theta = 0$$

$$\underline{\underline{B_\theta = \frac{\mu_0 I}{2\pi r}}}$$

only for $b > r > a$

(direction azimuthal : cf. RH screw) ¹⁰

Hence show that the *self inductance* of a length l of this cable is $L = \frac{\mu_0 l}{2\pi} \ln(b/a)$. [8]

Calculate the self-inductance:
(surface $dS = r \cdot dl$)

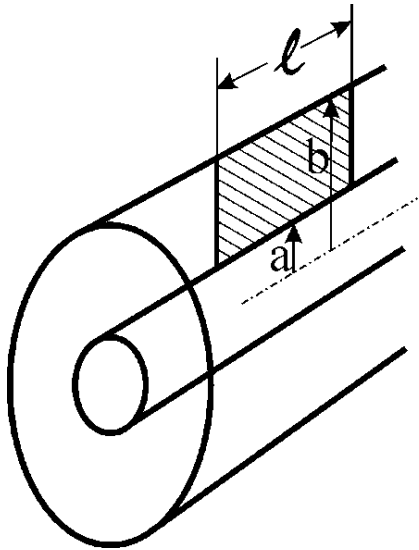

$$\Phi = \int \mathbf{B} \cdot d\mathbf{S} = \int_a^b \frac{\mu_0 I}{2\pi r} dr \cdot \ell = \frac{\mu_0 I}{2\pi} \ln\left(\frac{b}{a}\right) \cdot \ell$$

$$L = \frac{\Phi}{I} = \frac{\mu_0}{2\pi} \ln\left(\frac{b}{a}\right) \cdot \ell$$

Alternatively, use: $U_M = \frac{1}{2\mu_0} \int_{all\ space} B^2 dV$

$$\text{Here: } U_M = \frac{1}{2\mu_0} \int_a^b \left(\frac{\mu_0 I}{2\pi r}\right)^2 2\pi r dr \cdot \ell = \frac{1}{2} \frac{\mu_0 I^2}{2\pi} \ln\left(\frac{b}{a}\right) \cdot \ell$$

$$\text{Also, since: } U_M = \frac{1}{2} L I^2 \Rightarrow L = \frac{\mu_0}{2\pi} \ln\left(\frac{b}{a}\right) \cdot \ell$$

For the case where the inner cylinder is replaced by a solid wire, also of radius a , through-out which the current is uniformly distributed, sketch the variation of the magnitude of magnetic field with r over the range $r = 0$ to $r = 2b$.

[7]

Sketch the magnitude of B when the inner cylinder is replaced by a solid wire

for $r > a$: see before

(ratio of areas)

for $r < a$: $2\pi r B_\theta = \mu_0 I \cdot \frac{\pi r^2}{\pi a^2}$ thus $B_\theta = \frac{\mu_0 I}{2\pi a} \cdot \frac{r}{a}$

Co-axial cable

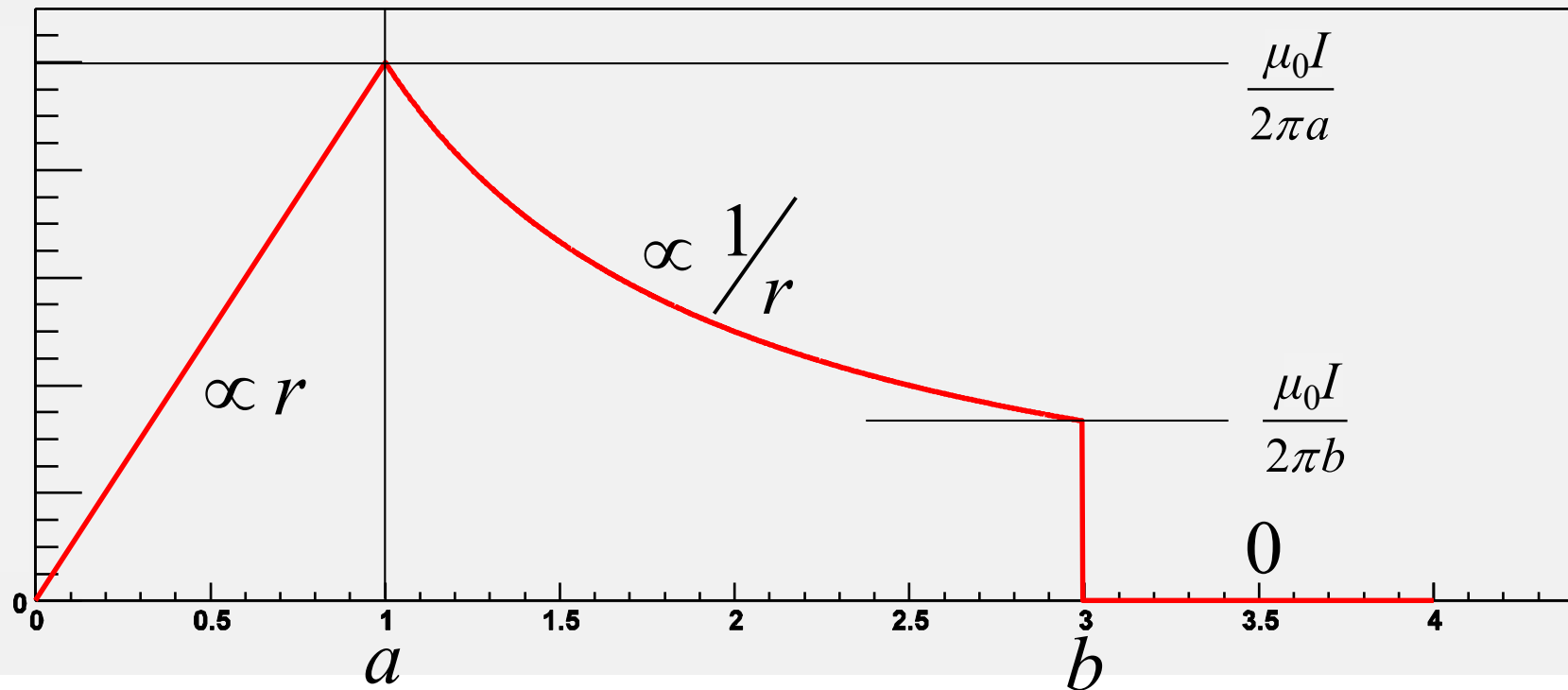

3 Electromagnetic Induction & Electrodynamics

3.1. State the laws of *electromagnetic induction*.

[3]

State the laws of electromagnetic induction

- **Faraday's Law (or the Universal Flux Rule) :**

The induced electromotive force (EMF) \mathcal{E} in any closed circuit is equal to (the negative of) the time rate of change of the magnetic flux Φ through the circuit :

$$\mathcal{E} = -\frac{d\Phi}{dt} = -\frac{d}{dt} \int_S \underline{\mathbf{B}} \cdot \underline{\mathbf{d}\mathbf{a}}$$

$$[\text{Note that : } \varepsilon = \oint \mathbf{E} \cdot d\mathbf{l}]$$

- **Lenz's Law :**

The induced EMF gives rise to a current whose magnetic field opposes the original change in magnetic flux that caused it (Lenz's Law *is* the minus sign in Faraday's Law)

A thin circular annular disc of outer radius a , inner radius $a/2$ and thickness d is made from a metal of resistivity ρ . Electrical contact is made to the disc through two stationary brushes of negligible impedance. The first of these extends around the entire outer periphery at radius a , while the second makes contact around the entire inner edge at radius $a/2$.

Faraday disc (thickness d).

Brushes around entire inner and outer perimeter.

Magnetic flux density parallel to axis of rotation (comes later).

$$r_{inner} = a/2$$

$$r_{outer} = a$$

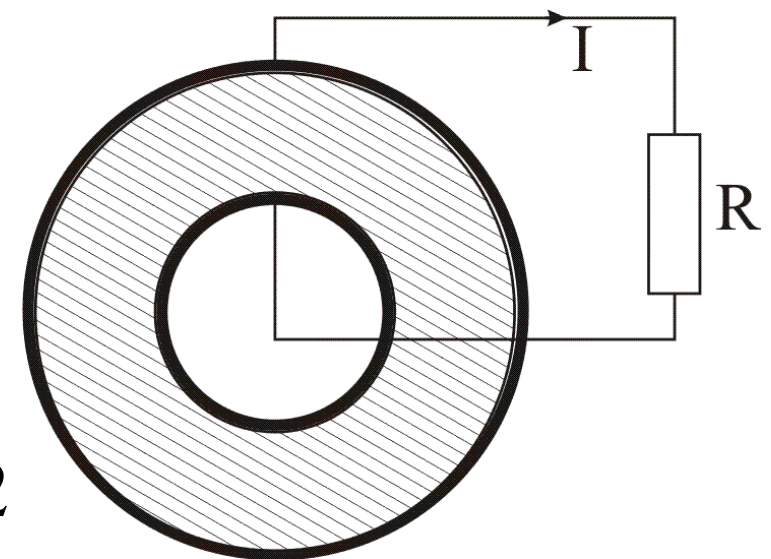

resistivity ρ

(a) Calculate the electrical resistance of this arrangement.

[10]

Calculate the electrical resistance of the disc

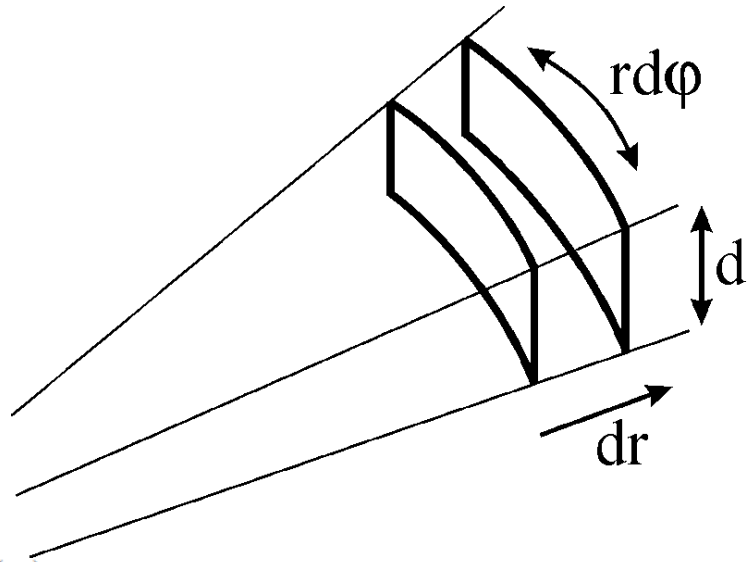

$$R_D = \rho \cdot \frac{\text{length}}{\text{area}} \quad (\rho = \text{resistivity})$$

$$= \int_{a/2}^a \rho \cdot \frac{dr}{2\pi r \cdot d} = \frac{\rho}{2\pi d} \cdot \ln(2)$$

(b) Derive an expression for the potential difference between the brushes if the disc rotates at angular velocity ω in a uniform magnetic induction \mathbf{B} parallel to the rotation axis.

[8]

Find the potential difference for the disc rotating in a magnetic flux density \mathbf{B}

$$\mathcal{E} = \int_{r=a/2}^{r=a} (\underline{\mathbf{v}} \times \underline{\mathbf{B}}) \cdot \underline{\mathbf{dr}} \quad \text{where } \underline{\mathbf{v}} \perp \underline{\mathbf{B}} \perp \underline{\mathbf{dr}} \text{ and } v = r\omega$$

$$\mathcal{E} = \int_{a/2}^a \omega B r dr = \frac{1}{2} \omega B \left(a^2 - \left(\frac{a}{2} \right)^2 \right) = \frac{3}{8} B a^2 \omega$$

(a) Calculate the electrical resistance of this arrangement.

[10]

Calculate the electrical resistance of the disc

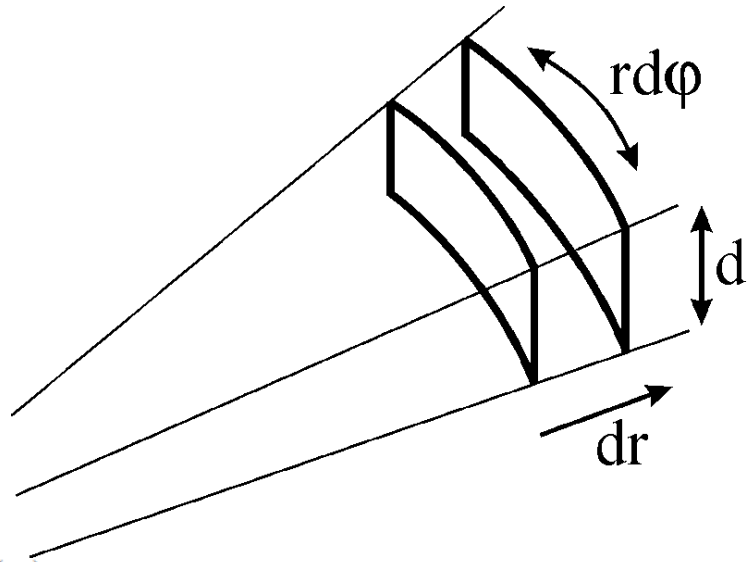

$$R_D = \rho \cdot \frac{\text{length}}{\text{area}} \quad (\rho = \text{resistivity})$$
$$= \int_{a/2}^a \rho \cdot \frac{dr}{2\pi r \cdot d} = \frac{\rho}{2\pi d} \cdot \ln(2)$$

(b) Derive an expression for the potential difference between the brushes if the disc rotates at angular velocity ω in a uniform magnetic induction \mathbf{B} parallel to the rotation axis.

[8]

Find the potential difference for the disc rotating in a magnetic flux density B

Alternative method:

(see lectures)

$$emf = \frac{\text{flux cut}}{\text{time}} = \frac{B \cdot \pi \left(a^2 - \left(\frac{a}{2} \right)^2 \right)}{2\pi / \omega} = \underline{\underline{\frac{3}{8} B a^2 \omega}}$$

16

- (c) What value of load resistor R connected between the brushes would allow maximum power to be delivered to the load while the disc rotates, as in (b)? [4]

Find the optimum value for a load resistor

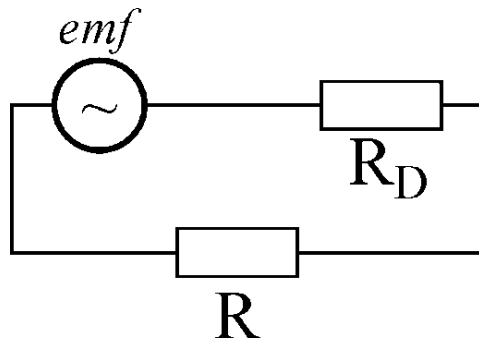

$$I = \frac{emf}{R_D + R}$$

Power in load: $P = I^2 R$

$$P = (emf)^2 \cdot \frac{R}{(R_D + R)^2}$$

$$\frac{\partial P}{\partial R} = 0: \quad 0 = (R_D + R)^2 \cdot 1 - 2(R_D + R) \cdot R$$

maximum power transfer for: $\underline{\underline{R = R_D}}$

3.2. A homopolar generator consists of a metal disc of radius a and a central axle which has radius $a/4$. The disc has resistivity ρ and thickness t . It is rotated in a uniform magnetic field B about an axis through the centre, which is parallel to B and perpendicular to the plane containing the disc, at an angular frequency ω . Thin ring brushes make good electrical contact with the disc near the axle and near the outer rim of the disc as shown.

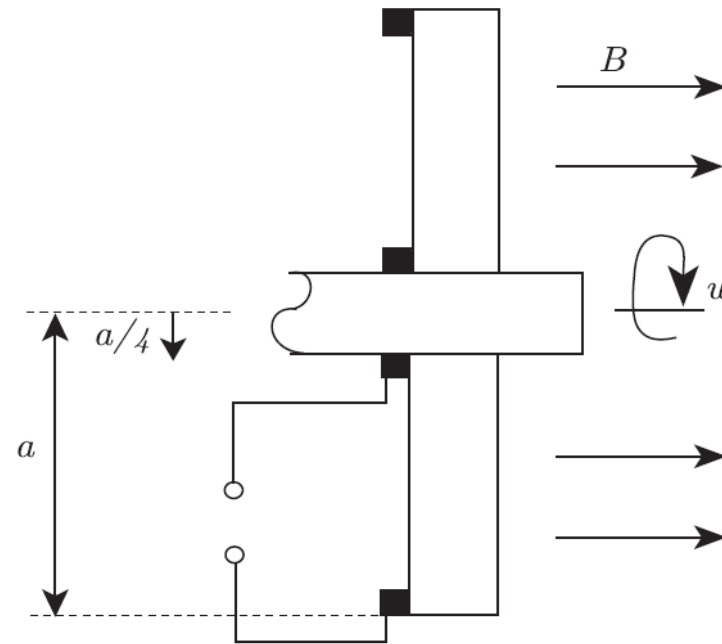

(a) Calculate the resistance of the disc R_D measured between the brushes. [7]

$$R = \rho \cdot \frac{\ell}{\text{area}} \quad \text{here: } \text{area}(r) = 2\pi r \cdot t \quad \text{As before}$$

$$\underline{\underline{R_D}} = \rho \cdot \int_{a/4}^a \frac{dr}{2\pi r t} = \frac{\rho}{2\pi t} \cdot \ln(4) = \underline{\underline{\frac{\rho \ln(2)}{\pi t}}}$$

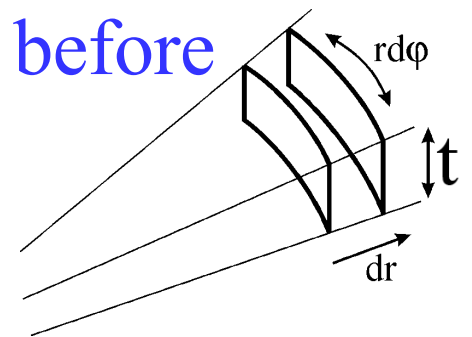

(b) Show that the potential difference between the brushes is $(15/32)\omega Ba^2$.

[7]

emf – same as before :

$$\mathcal{E} = \int_{r=a/4}^{r=a} (\underline{\mathbf{v}} \times \underline{\mathbf{B}}) \cdot \underline{\mathbf{dr}} \quad \text{where } \underline{\mathbf{v}} \perp \underline{\mathbf{B}} \perp \underline{\mathbf{dr}} \text{ and } v = r\omega$$

$$\mathcal{E} = \int_{a/4}^a \omega B r dr = \frac{1}{2}\omega B \left(a^2 - \left(\frac{a}{4}\right)^2 \right) = \frac{15}{32}Ba^2\omega$$

(c) A load resistance R_L is connected across the generator and the drive is removed. Show that, in the absence of mechanical friction, the time τ taken for the disc to slow down to half its initial angular speed is

$$\tau = \left(\frac{32}{15}\right)^2 \times \left[\frac{m(R_L + R_D) \ln 2}{2a^2 B^2} \right]. \quad [8]$$

$$E_{rot} = \frac{1}{2} I \omega^2 = \frac{1}{4} m a^2 \omega^2 \quad [1]$$

(NB, there is a mistake in this question: $I_b = \frac{1}{2} m a^2$ is assumed, but for an annulus $a/4 \rightarrow a$ with the same mass, I is a factor 17/16 larger)

$$\frac{dE_{rot}}{dt} = -P_{dissipated} = -\frac{(emf)^2}{R_D + R_L} = -\left(\frac{15}{32}\right)^2 \cdot \frac{B^2 a^4}{R_D + R_L} \cdot \omega^2$$

and $\omega^2 = \frac{4E_{rot}}{ma^2}$ (from [1])

$$\frac{dE_{rot}}{dt} = -\left(\frac{15}{32}\right)^2 \cdot \frac{4B^2 a^2}{m(R_D + R_L)} E_{rot}$$

Integrate : $\ln\left(\frac{E_{rot}(t)}{E_{rot}(0)}\right) = -\left(\frac{15}{32}\right)^2 \cdot \frac{4B^2 a^2}{m(R_D + R_L)} \cdot t$

"half its angular speed": $\frac{E_{rot}(t)}{E_{rot}(0)} = \frac{1}{4}$ (from [1])

$$\tau = \frac{\left(\frac{32}{15}\right)^2 \cdot m(R_D + R_L) \ln(2)}{2a^2 B^2}$$

3.3. A vertical square loop of wire with sides a is falling with velocity v as shown in the figure from a region of horizontal magnetic induction B into a region where $B = 0$. If the resistance of the loop is R , show that the magnitude of the current in the loop is

$$I = \frac{Bav}{R}. \quad [8]$$

A vertical loop is falling as shown below.
Calculate the current in the loop.

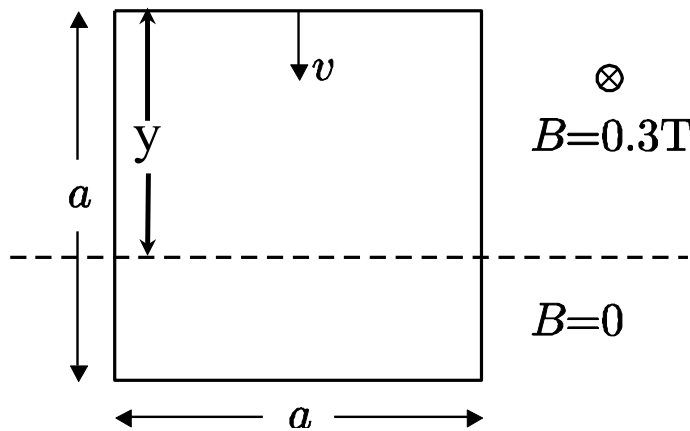

$$\Phi = B \cdot \text{area} = B \cdot a \cdot y$$

$$emf = -\frac{d\Phi}{dt} = -B \cdot a \cdot \frac{dy}{dt} = B \cdot a \cdot v$$

$$R = \frac{V}{I} \quad \rightarrow \quad \underline{\underline{I = \frac{B \cdot a \cdot v}{R}}}$$

Describe the forces acting on the loop due to the magnetic field, and indicate their directions.

[7]

Describe the forces acting on the loop due to the magnetic field, and indicate their directions:

$$\mathbf{F} = q \cdot \mathbf{v} \times \mathbf{B}$$

$$F = I \cdot a \cdot B$$

- Current (+e) clockwise
- Force on these moving charges
- Sideways forces cancel
- Remaining force has decelerating effect

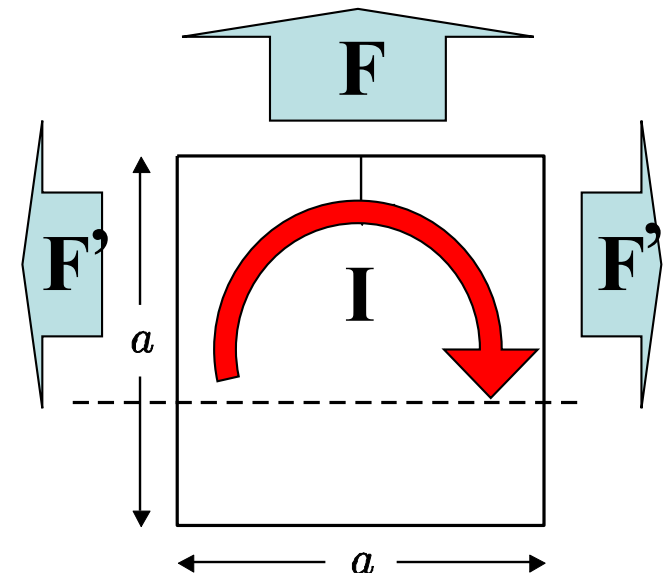

If $a = 10\text{ cm}$ and the wire has a diameter of 1 mm and is made of copper (resistivity = $1.7 \times 10^{-8}\ \Omega\text{m}$, density = 8960 kg m^{-3}), and $B = 0.3\text{ Tesla}$, calculate the steady state velocity, if this is reached while the upper arm of the loop is still in the magnetic field. [7]

Find R: $a = 10\text{cm}$, $D = 1\text{mm}$, $\rho_e = 1.7 \cdot 10^{-8}\ \Omega\text{m}$

$$R = \rho_e \cdot \frac{4a}{\frac{\pi}{4} D^2} = 1.7 \cdot 10^{-8}\ \Omega\text{m} \cdot \frac{4 \cdot 0.1\text{m}}{\frac{\pi}{4} \cdot 10^{-6}\text{m}^2} = 8.66 \cdot 10^{-3}\ \Omega$$

... and the mass: $m = \rho_m \cdot V$ with $\rho_m = 8960\ \frac{\text{kg}}{\text{m}^3}$

$$m = 8960\ \frac{\text{kg}}{\text{m}^3} \cdot 0.4\text{m} \cdot \frac{\pi}{4} \cdot 10^{-6}\text{m}^2 = 2.814 \cdot 10^{-3}\ \text{kg}$$

Calculate the steady state velocity, if this is reached while the upper arm of the loop is still in the magnetic field.

$$F = I \cdot a \cdot B = \frac{B \cdot a \cdot v}{R} \cdot a \cdot B = m \cdot g \quad \text{magnetic force} = \text{gravitational force}$$

$$\underline{\underline{v}} = \frac{mgR}{a^2 B^2} = \underline{\underline{0.0266\ \text{m/s}}}$$

3.4. Two parallel rails separated by a distance d lie along the direction of greatest slope on an incline making an angle θ with the horizontal. A flat bar of mass m rests horizontally across the rails at the top of the incline. Both the bar and the rails are good conductors and the rails are joined by a large resistance R at the bottom of the incline. A uniform, vertical magnetic field of flux density B exists throughout the region.

The bar is released from rest and slides freely down the rails, remaining always horizontal (i.e. perpendicular to the rails). Find an expression for the induced current and hence find the equation of motion of the bar.

[10]

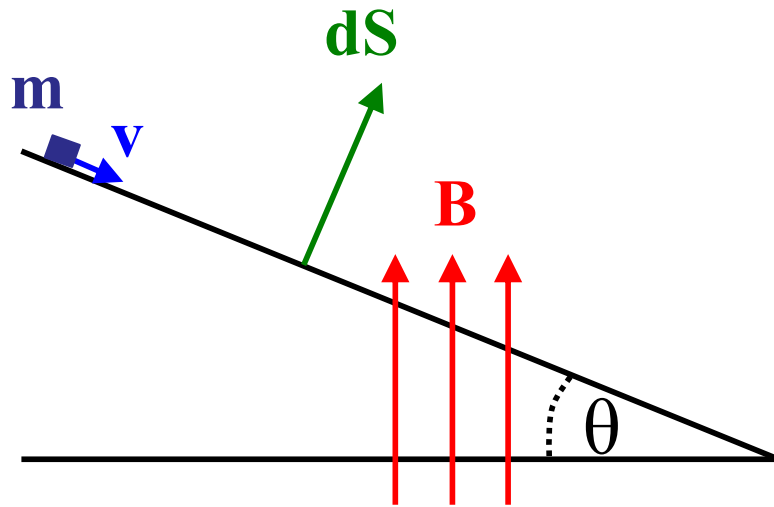

side view

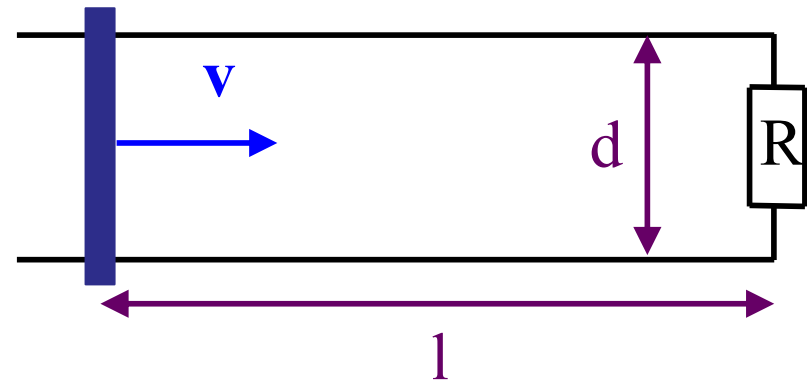

top view

Induced e.m.f. $V_{emf} = -\frac{d}{dt} \int \mathbf{B} \cdot d\mathbf{S} = B \cos\theta \frac{dA}{dt}$

where $A = d l$

$$V_{emf} = -B \cos\theta d \frac{dl}{dt} = B \cos\theta d v$$

Induced current: $I = V_{emf} / R$

Equation of Motion - consider magnetic (Lorentz) force on current-carrying bar: $d\mathbf{F} = I d\mathbf{l} \times \mathbf{B}$

$$\rightarrow F_{para} = I d B \cos\theta = V_{emf} / R d B \cos\theta = B^2 d^2 \cos^2\theta v / R$$

Equation of Motion: $m \frac{d}{dt} v = \underbrace{mg \sin\theta}_{\text{gravitational}} - \underbrace{B^2 d^2 \cos^2\theta v / R}_{\text{magnetic}}$

$$\rightarrow \frac{d}{dt} v + \underbrace{B^2 d^2 \cos^2\theta / (mR)}_k v = g \sin\theta$$

Solving Equation of Motion: $\frac{d}{dt} v + k v = g \sin\theta$

try $v = A \exp(-k t) + B$ $\xrightarrow{\text{insert into EoM}}$ $B = \sin\theta g/k$

boundary condition: at $t = 0, v = 0 \rightarrow A = -B$

$$\rightarrow v = \sin\theta g/k (1 - \exp(-k t))$$

Show that the bar will approach a constant speed and find an expression for this speed. [4]

for $t \rightarrow \infty$, constant velocity: $v_{\infty} = \sin\theta g/k$

$$\rightarrow v_{\infty} = g m R \sin\theta / (B^2 d^2 \cos^2\theta)$$

3.5. In a particular experiment, a particle of mass m and charge $+q$ moves with speed v along the x -axis towards increasing x . Between $x = 0$ and $x = b$, there is a region of uniform magnetic field \mathbf{B} in the y -direction. Deduce the conditions under which the particle will reach the region $x > b$. In the event that it does reach this region, find an expression for the angle to the x -axis at which it will enter it. [10]

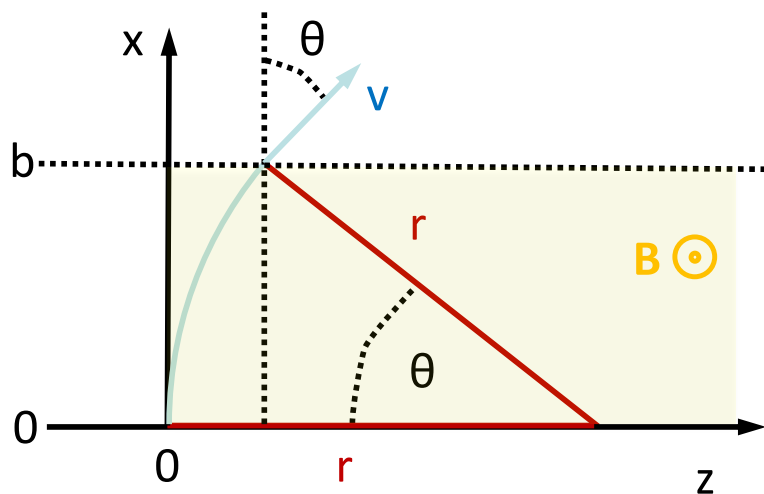

Lorentz force acts perpendicular to \mathbf{v} and \mathbf{B} .

Particle is forced onto circular path:
 $F = q v B = mv^2/r$
 $r = mv/(qB)$

The particle will reach the region $x > b$ if $b < r$, so need:

$$b < mv/(qB)$$

If it reaches the region, it enters it at angle θ with $\sin \theta = b/r$

$$\sin \theta = b q B / (m v)$$

In a second experiment, the same particle is accelerated from rest by a constant electric field \mathbf{E} acting over a length d . The particle then encounters a region of constant magnetic field \mathbf{B} perpendicular to its velocity, as shown in the figure below. Deduce the magnitude $|\mathbf{B}|$ such that the particle will re-enter the region of constant electric field at a distance d from the point at which it left. Assuming this value of $|\mathbf{B}|$, sketch the particle's trajectory in the region of constant magnetic field and derive an expression for the time spent there. [10]

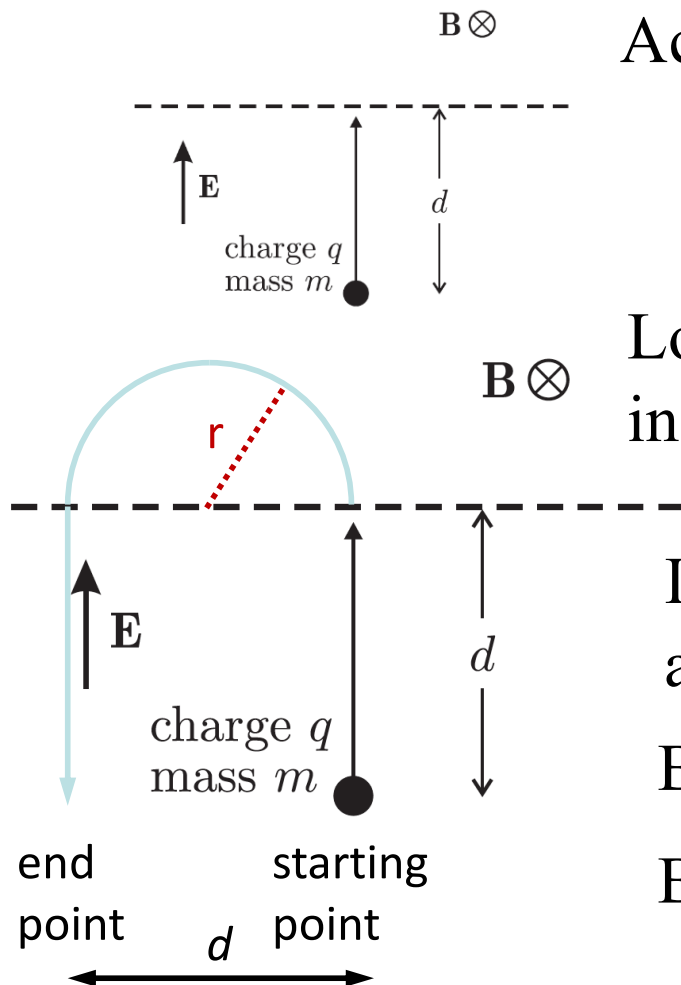

Acceleration in E-field provides kinetic energy:

$$\frac{1}{2} m v^2 = q V = q E d$$

$$v = (2qEd/m)^{1/2}$$

Lorentz force provides centripetal acceleration in the second region (with B-field): $q v B = mv^2/r$

If the particle is to re-enter the electric field at a distance d from where it left, we need $r=d/2$:

$$B = 2mv/(qd) = 2m (2qEd/m)^{1/2}/(qd)$$

$$B = 2 (2mE/(qd))^{\frac{1}{2}} \text{ is required}$$

$$\text{Time spent} = [1/2 \text{ circumference}] / [\text{velocity}] = \pi r / v$$

4 Electromagnetic Waves

4.1. By considering Ampere's law applied to a parallel plate capacitor being charged by a current I_C , explain why it is necessary to introduce a displacement current I_d given by

$$I_d = \epsilon_0 A \frac{dE}{dt},$$

where A is the area of the plates and E is the electric field strength between the plates of the capacitor.

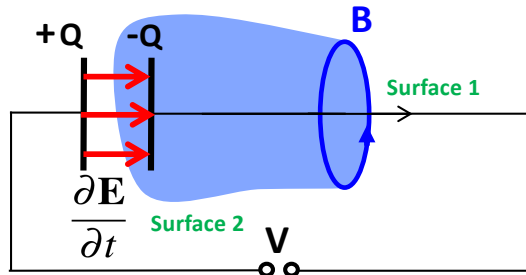

Surface 1:

$$\oint \mathbf{B} \cdot d\mathbf{l} = \mu_0 I$$

Gauss inside capacitor [7]

$$\int E \cdot dA = EA = \frac{Q}{\epsilon_0}$$

Surface 2: $I_d = \frac{dQ}{dt} = \epsilon_0 A \frac{dE}{dt}$

Show how Ampere's law with the addition of the displacement current can be written in differential form [5]

$$\oint \mathbf{B} \cdot d\mathbf{l} = \mu_0 I_C + \mu_0 I_D = \mu_0 \left[\iint \mathbf{J}_C \cdot d\mathbf{A} + \iint \mathbf{J}_D \cdot d\mathbf{A} \right]$$

Stokes: $\oint \mathbf{B} \cdot d\mathbf{l} = \iint \nabla \times \mathbf{B} \cdot d\mathbf{A}$

\mathbf{J} is the current density

$$\therefore \nabla \times \mathbf{B} = \mu_0 \mathbf{J} + \mu_0 \epsilon_0 \dot{\mathbf{E}}$$

Write down Maxwell's equations for fields in a vacuum devoid of charges and currents.
Deduce from these equations the wave equation for \mathbf{E} and the speed of these waves.

[8]

Maxwell's
equations in free
space:

$$\begin{aligned}\nabla \cdot \mathbf{E} &= 0 & \nabla \cdot \mathbf{B} &= 0 \\ \nabla \times \mathbf{E} &= -\dot{\mathbf{B}} & \nabla \times \mathbf{B} &= \mu_0 \varepsilon_0 \dot{\mathbf{E}}\end{aligned}$$

Wave equation
from Maxwell
equations:

$$\nabla \times \nabla \times \mathbf{E} = -\nabla \times \dot{\mathbf{B}} = -\mu_0 \varepsilon_0 \ddot{\mathbf{E}}$$

$$\nabla \times \nabla \times \mathbf{E} = \underbrace{\nabla(\nabla \cdot \mathbf{E})}_{=0} - \nabla^2 \mathbf{E}$$

$$\text{wave equation: } \nabla^2 \mathbf{E} - \mu_0 \varepsilon_0 \ddot{\mathbf{E}} = 0$$

Simplest form
is a plane
wave solution

$$\mathbf{E} = \mathbf{E}_0 \exp[i(\omega t \mp \mathbf{k} \cdot \mathbf{r})] : \quad -k^2 + \mu_0 \varepsilon_0 \omega^2 = 0$$

(And similarly for \mathbf{B})

$$\frac{\omega}{k} = \pm \frac{1}{\sqrt{\mu_0 \varepsilon_0}} = \pm c \quad (\text{speed of light})$$

4.2. State Maxwell's equations appropriate to fields in a vacuum where there are charges and currents. [4]

$$\begin{aligned}\nabla \cdot \mathbf{E} &= \frac{\rho}{\epsilon_0} & \nabla \cdot \mathbf{B} &= 0 \\ \nabla \times \mathbf{E} &= -\dot{\mathbf{B}} & \nabla \times \mathbf{B} &= \mu_0 (\mathbf{J}_C + \epsilon_0 \dot{\mathbf{E}})\end{aligned}$$

Show that Maxwell's equations, in a vacuum devoid of charges and currents, lead to wave equations for the electric and magnetic fields and deduce the speed of propagation of the waves. [5]

Exactly as before, wave equation (for E and B fields):

$$\text{from } \exp[i(\omega t \mp \underline{\mathbf{k}} \cdot \underline{\mathbf{r}})]: \quad -k^2 + \mu_0 \epsilon_0 \omega^2 = 0$$

$$\frac{\omega}{k} = \pm \frac{1}{\sqrt{\mu_0 \epsilon_0}} = \pm c \quad (\text{speed of light})$$

Show that a plane wave solution may be obtained with field components E_y and B_x , with all other components zero. Deduce the direction of propagation and find the relation between the magnitudes of E_y and B_x . Draw a sketch showing the relative orientation of the field components and the direction of propagation. [11]

$$\begin{aligned} \underline{\mathbf{E}} &= \underline{\mathbf{E}}_0 \exp[i(\omega t \mp \mathbf{k} \cdot \mathbf{r})] && \rightarrow \text{direction of propagation is} \\ \underline{\nabla} \cdot \underline{\mathbf{E}} &= -i\mathbf{k} \cdot \underline{\mathbf{E}} = 0 && \text{perpendicular to both } \underline{\mathbf{E}} \text{ and } \underline{\mathbf{B}}: \\ \underline{\nabla} \cdot \underline{\mathbf{B}} &= -i\mathbf{k} \cdot \underline{\mathbf{B}} = 0 && \underline{\mathbf{E}} = E_y \hat{\mathbf{y}} = E_0 \exp[i(\omega t \mp kz)] \hat{\mathbf{y}} \\ &&& \underline{\mathbf{B}} = B_x \hat{\mathbf{x}} = B_0 \exp[i(\omega t \mp kz)] \hat{\mathbf{y}} \end{aligned}$$

Plane wave solution with E_y and B_x only:

$$\nabla \times \mathbf{E} = \begin{vmatrix} i & j & k \\ \partial_x & \partial_y & \partial_z \\ 0 & E_y & 0 \end{vmatrix} = \begin{pmatrix} -\frac{\partial E_y}{\partial z} \\ 0 \\ 0 \end{pmatrix} = -\dot{\mathbf{B}} = \begin{pmatrix} -\frac{\partial B_x}{\partial t} \\ 0 \\ 0 \end{pmatrix}$$

$E_y \equiv E_y(z)$ only,
not a function of x

$$E_y = \mp \frac{\omega}{k} B_x = \mp c B_x$$

$$|E_y| = c |B_x|$$

Sketch :

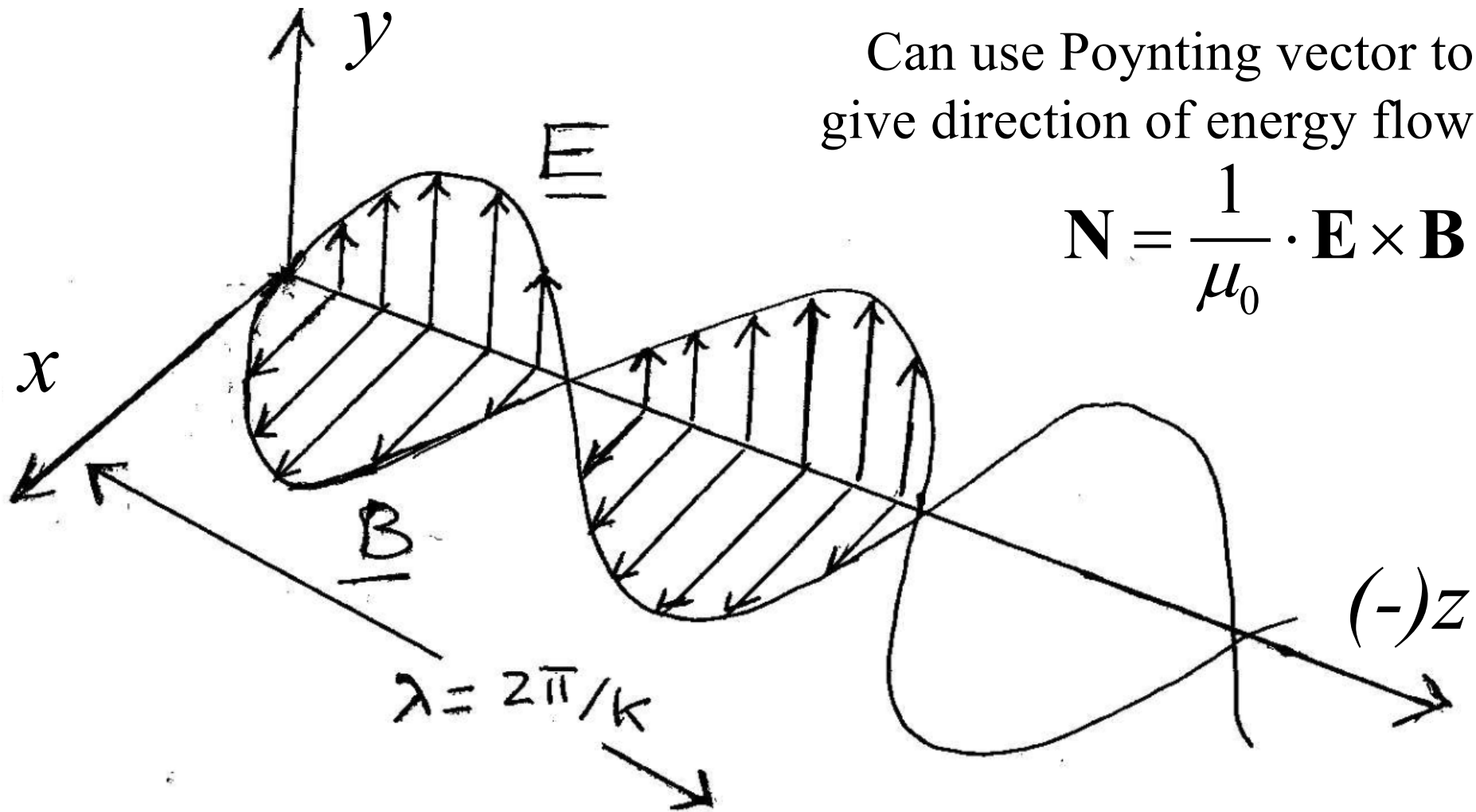

Can use Poynting vector to give direction of energy flow

$$\mathbf{N} = \frac{1}{\mu_0} \cdot \mathbf{E} \times \mathbf{B}$$

Or in the other direction ...

That's all!

Good luck in Prelims !!!